

Surname	Centre Number	Candidate Number
Other Names		



LEVEL 1/LEVEL 2 AWARD

9793/01



S16-9793-01

**ENGINEERING – Unit 3
Solving Engineering Problems
(VOCATIONAL)**

P.M. MONDAY, 6 June 2016

1 hour 30 minutes

For Examiner's use only		
Question	Maximum Mark	Mark Awarded
1.	24	
2.	16	
3.	20	
Total	60	

ADDITIONAL MATERIALS

In addition to this paper you may require a calculator and a ruler.

INSTRUCTIONS TO CANDIDATES

Use black ink or black ball-point pen.

Write your name, centre number and candidate number in the spaces at the top of this page.

Answer **all** questions.

Write your answers in the spaces provided in this booklet. Where the space is not sufficient for your answers, continue at the back of the book, taking care to number the continuation correctly.

INFORMATION FOR CANDIDATES

The total number of marks for this paper is 60.

The number of marks is given in brackets at the end of each question or part-question.

You are reminded of the necessity for good English and orderly presentation in your answers.

Answer **all** questions in the spaces provided.

1. The image below shows a modern style of scooter. The scooter is a human-powered land vehicle with a handlebar, frame, deck, braking system and wheels that is propelled by a rider pushing off the ground.



- (a) Describe **two** functions required of the handlebar. [2]

.....

.....

.....

- (b) (i) Complete the table below, suggesting a suitable material or classification for **each** part of the scooter. *An example has been done for you.*

Part	Material	Classification
Frame	Steel	Ferrous
Handlebars	[1]	Composite
Wheel rim	Aluminium alloy	[1]
Brake lever	ABS (Acrylonitrile Butadiene Styrene)	[1]

(ii) The main frame of the scooter is manufactured from tubular steel. Explain **two** benefits to the manufacturer of using this material.

Benefit 1: [2]

.....
.....

Benefit 2: [2]

.....
.....

(c) Name **one** method of permanently joining the steel tubes during the manufacture of the scooter frame. [1]

.....

(d) State **two** possible reasons for the application of a surface finish to the frame tubes.

Reason 1: [1]

.....
.....

Reason 2: [1]

.....
.....

(e) Composite materials have aided the development of the modern scooter.

(i) Explain what is meant by the term 'composite material'. [2]

.....
.....

(ii) Explain an advantage and a disadvantage of using composite materials to manufacture the scooter frame.

Advantage:

[2]

.....

.....

.....

Disadvantage:

[2]

.....

.....

.....

(f) One of the main reasons a material is chosen for a product is the material properties.

Using the words below, identify a suitable property for **each** component and explain the reason for your choice. [6]



Tensile strength

Hardness

Ductility

Elasticity

Conductivity

Component	Property	Reason for chosen property
Wheel bearing 	Hardness	The balls or rollers have been suitably hardened to prolong the life of the wheel bearing.
Inflatable tyre 		
Brake cable 		

2. The world of engineering has been influenced by developments in technology.

Below are images of a modern cordless drill and an older mains operated drill.



(a) Use **three** examples to describe how modern technology has made the modern cordless drill **safer** to use.

Example 1:

[2]

.....

.....

Example 2:

[2]

.....

.....

Example 3:

[2]

.....

.....

9793
010005

BLANK PAGE

3. (a) Below is an orthographic projection drawing of a 'V block'.

Using the grid provided produce a scaled isometric drawing of the 'V block'. [8]

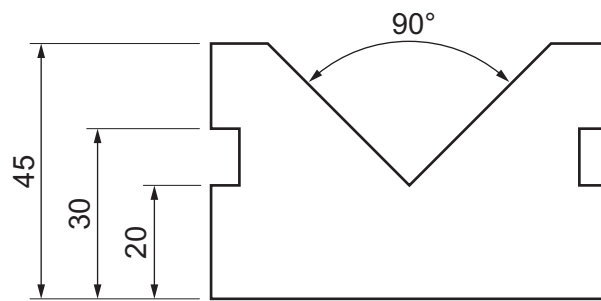
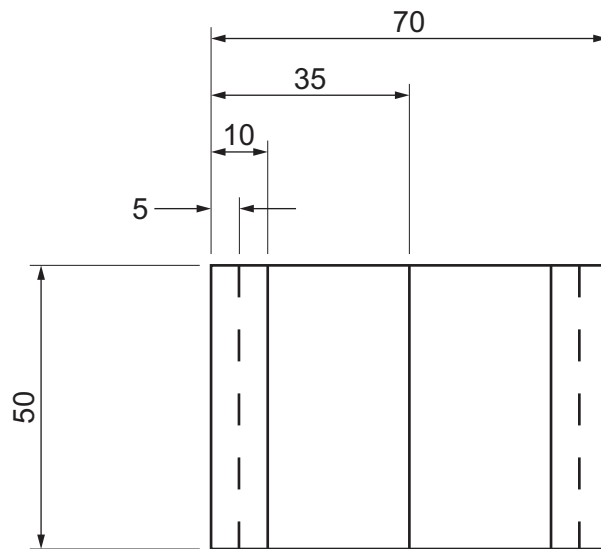

ALL DIMENSIONS IN MM



NOTE: 5MM ISOMETRIC GRID

(b) Below is an orthographic drawing of an engineered component.

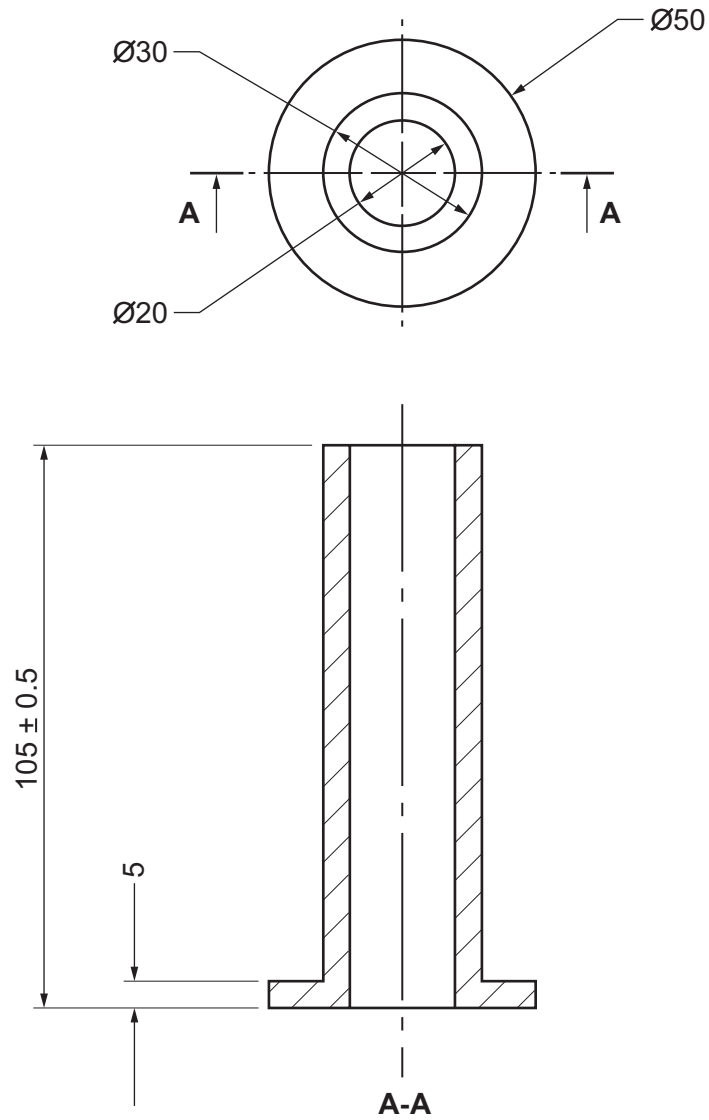

Explain the purpose of the hatched lines seen in the view labelled 'A-A'.

[2]

.....

.....

